



## 236 - First studies in reactor concepts for Thermochemical Storage

H.A. Zondag<sup>1\*</sup>, Alex Kalbasenka<sup>1</sup>, Martijn van Essen<sup>1</sup>,  
Lucas Bleijendaal<sup>1</sup>, Roelof Schuitema<sup>1</sup>, Wim van Helden<sup>1</sup>, Lucienne Krosse<sup>2</sup>

<sup>1</sup> ECN, Energy Research Centre of the Netherlands, P.O. Box 1, 1755 ZG Petten, The Netherlands

<sup>2</sup>TNO, P.O.Box 342, 7300 AH, Apeldoorn, The Netherlands

\* Corresponding Author, Zondag@ecn.nl

### Abstract

This paper summarises the findings of a parameter study on a TCM reactor, and in addition presents first calculations on the dimensioning of three concepts for dehydration reactors.

### 1. Introduction

Traditional heat storage techniques have a number of disadvantages for long-term heat storage, such as substantial heat loss and relatively low energy density (large volume). As an alternative, it is possible to store energy by means of chemical processes in thermochemical materials (TCM), making use of the reversible chemical reaction  $A(s) + B(g) \rightleftharpoons C(s) + \text{heat}$ . Interesting reactants are low cost, non-toxic, non-corrosive, have sufficient energy storage density and have reaction temperatures in the proper range. These requirements are fulfilled by a number of salt hydrates. In a previous study (Visscher et al., 2004), magnesium sulphate has been identified as a potentially interesting storage material, by means of the reaction  $MgSO_4(s) + 7H_2O(g) \rightleftharpoons MgSO_4 \cdot 7H_2O(s) + 411 \text{ kJ per mole of } MgSO_4$ . This material could be interesting for seasonal storage of solar heat. During winter, when heat is needed for e.g. residential heating, the magnesium sulphate is hydrated, producing heat. During summer, the hydrate is dehydrated by heat from a solar collector, which can be regarded as charging of the material. Once the chemical reaction has taken place, the solar heat can be stored in this way for a long time period without losses.

### 2. Separate reactor or integrated reactor

The hydration and dehydration of the TCM material take place in a reactor. This may be a separate reactor or the reactor may be integrated in the storage, as shown in the systems presented in Fig. 1.

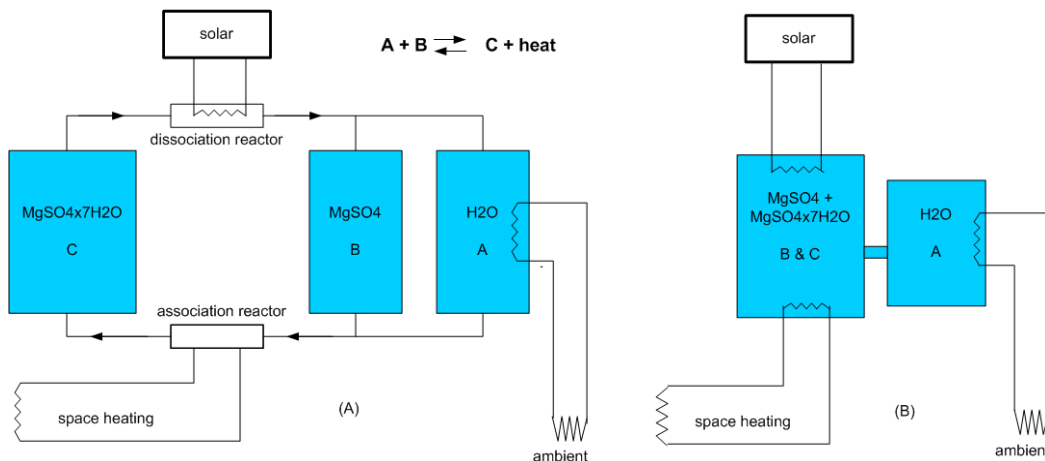

Fig. 1. (a) separate reactor, (b) reactor integrated in storage.



If the TCM material is a solid, nowadays integrated reactors are used. This has the advantage that it is not necessary to transport the solid material. However, for large storages such as seasonal storage, this also has disadvantages such as a larger sensible heat loss, especially if the storage is not compartmented since then the whole reactor content has to be heated up before dehydration occurs. Also the required heat exchange area is much larger than for a separate reactor. In a separate reactor, it is possible to heat up only the required amount of TCM, thereby making the charging process much more efficient. Similar benefits occur on discharging the material. Also, the heat- and vapour transfer can be optimised within a separate reactor by stirring of the material.

### 3. Reactor boundary conditions

#### 3.1 TCM reactor system

A parametric study was carried out for a TCM system for seasonal storage. A schematic layout of this system is shown in Fig. 2. A 200 liter water tank was added to the system in order to lower the power demands for the TCM storage. In this way, the water tank is used to supply peak power (e.g. shower peaks), while the TCM storage can recharge the water tank afterwards at a lower power level. The collector system is designed in such a way that the water tank is preferentially loaded. Only if the water tank has reached its maximum temperature, the TCM storage is charged with the excess heat of the solar array. The TCM storage consists of 3 vessels: vessel C containing the hydrated salt, vessel B containing the dehydrated salt and vessel A containing the water vapour (in condensed form). On charging the storage, the hydrated salt from container C is fed to a dissociation reactor that is heated by a vacuum collector array, whereby the water vapour is released from the salt. The hot dehydrated salt is fed to B and the water vapour to A, where it condenses. On discharging the storage, the dehydrated salt is fed to an association reactor, where water vapour is again absorbed and the released heat is transferred to a water storage. The water vapour is produced by evaporating the water in tank A by means of heat from the borehole.

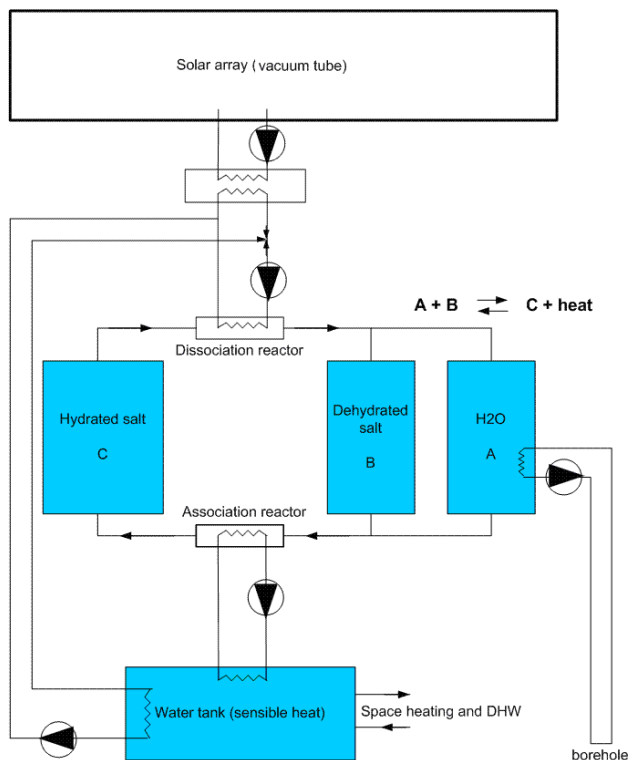

Fig. 2. TCM reactor system.



### 3.2 TCM parameter study

A parametric study has been carried out, in which the solar fraction of a thermochemical storage system for a low-energy house (6 GJ space heating) with a 40/25C low-temperature heating system and 9 GJ domestic hot water) was calculated as a function of collector area, collector type, charge and discharge temperatures, charge and discharge power, and reactor heat capacity and insulation (Zondag et al., 2008). Some typical results are displayed in Fig. 3 and Fig. 4. These calculations show an idealised case, in which good vacuum tubes were used, as well as a collector piping loop without heat loss, 100% efficient backup heaters and optimised TCM material (very fast reaction kinetics, ideal conductivity, small temperature hysteresis). All areas in the graphs refer to aperture.

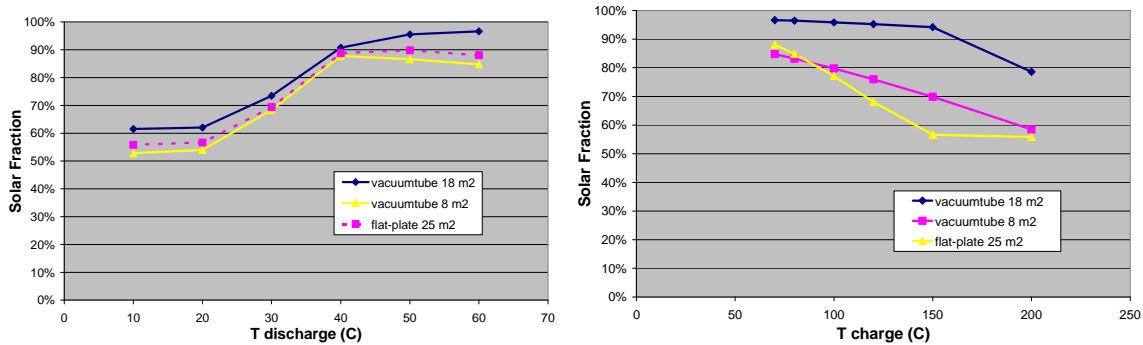

Fig. 3. Solar Fraction versus charge and discharge temperatures of TCM storage

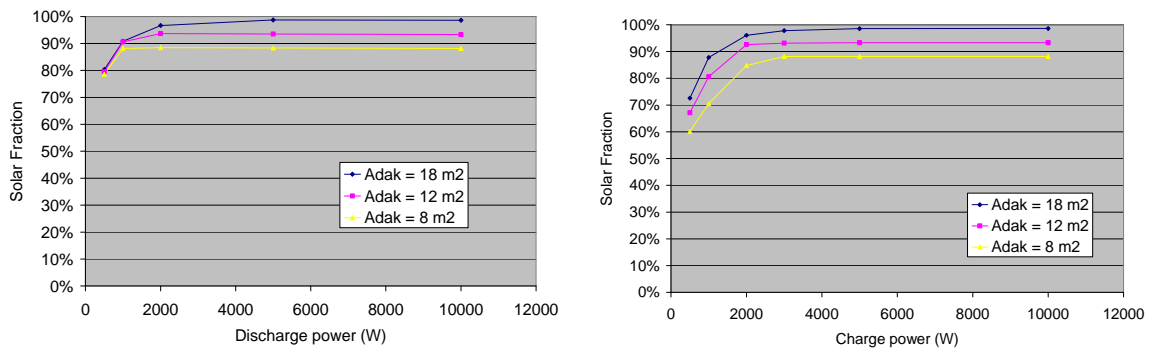

Fig. 4. Solar Fraction versus charge and discharge power of TCM storage

From the simulations, the following conclusions can be drawn:

- The water storage strongly reduces the demands on the TCM storage. By means of the water storage (1) the TCM storage material has to go through less cycles, reducing the requirements on the cyclability of the material, (2) the discharge power of the TCM storage can be strongly reduced to about 1-2 kW, (3) it is less important to be able to supply high tap water temperatures with the TCM storage.
- The main aim of the TCM storage should be to cover the space heating demand. The domestic hot water demand can be largely covered directly by the vacuum tube array in combination with the water storage tank. The requirement for the TCM tank to cover also fully the domestic hot water results in only a modest increase in the overall solar fraction, while it substantially increases the required TCM discharge temperature. A high required discharge temperature (= hydration temperature) can substantially reduce the performance of the salt (see Van Essen et al., 2008).



- The effect of the charging temperature of the TCM on the system performance depends strongly on the type of collectors used and the system dimensioning; generally, good vacuum tube collectors are preferred for TCM charging, since relatively high charging temperatures have to be reached. In addition, the simulations show that if the collector array is dimensioned large, an increase in the required TCM charge temperature only reduces the number of standstill hours, without much effect on the solar fraction. However, if the solar collector array is dimensioned small, an increase in required TCM charge temperature will imply that the storage is not filled anymore, thereby substantially reducing the solar fraction that can be obtained (see Fig. 3b).

In addition, the effect of the thermal capacity of the TCM reactor was investigated. It was found that the insulation of the TCM reactor was increasingly critical for reactors with a high thermal capacity, the worst case being that of a reactor integrated into an insufficiently insulated non-compartmented storage (as shown in Fig 1b).

#### 4. Design options for separate reactors

An important design specification for a TCM system is the required thermal power input, which is related to the amount of material in the reactor and how fast the solar heat can be fed to the material. Typically, this process is complicated by the low thermal bed conductivity of the TCM powder, which is due to the low conductivity of the gas in the pores between the particles. Also the water vapour transport out of the layer of TCM powder is critical, and insufficient vapour transport out of the material may result in unwanted melting. One can try to improve the heat and vapour transfer simultaneously by stirring, thereby speeding up the conversion. Three design cases have been evaluated for dehydration reactor volume in the following paragraphs, under the assumptions that the reactor power required is 3 kW (see Fig 4) and that heat transport is the limiting factor.

##### 4.1 TCM fluidised bed reactor

A fluidised bed reactor (see Fig. 5a) creates very good mixing of the powder, thereby improving strongly the vapour transport and the heat transfer. Fig. 5b shows that for small particles, the fluidisation velocity is small, limiting the power required for the fluidisation, while the heat transfer to the embedded heat exchanger is strongly increased. However, the fluidisation may cause breakup of TCM particles that are fragile already due to the cracks caused by repetitive hydration and dehydration. The resulting fine dust may be blown out of the fluidised bed reactor, thereby reducing the amount of active material. Also, this very fine powder cannot be fluidised properly.

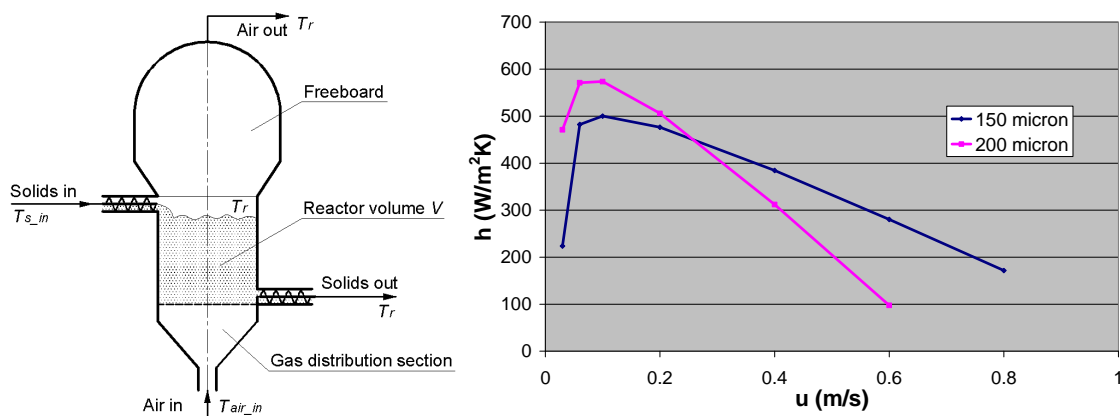

Fig. 5. (a) TCM fluidised bed reactor, (b) fluidised bed heat transfer (VDI Wärmeatlas, 1991)



For the case of dehydration of the TCM in a 3 kW reactor, assuming 200 micron particles and an effective heat transfer of about  $350 \text{ W/m}^2\text{K}$  to the immersed plate heat exchanger (consisting of 11 parallel plates of  $7.5 \text{ cm} \times 19 \text{ cm}$  each), this would lead to a reactor fluidisation section (excluding the freeboard and the gas distribution section) of about 20 cm in length and 11 cm diameter, in which about 40% of the open volume would be filled with TCM, while about 30% of the reactor volume is taken up by the heat exchanger volume. Due to the low fluidisation velocity (resulting from the small particle size), the power required for fluidisation is in the order of a few Watt. This seems promisingly low, provided that the pressure drop in the porous support and other parts of the reactor can also be kept small.

#### 4.2 TCM extruder reactor system

In an extruder reactor (see Fig. 6a), the extruder transports the material and additionally causes stirring, thereby improving vapour and heat transport. The effectiveness of the transport depends on the rotational speed of the screw. The heat can be added or removed by means of either a jacket around the screw tube, or a hollow screw. This would be a convenient way of integrating the means of transport required for the powder and the reactor. If there is risk of the TCM material sticking to the screw, a system with two parallel self-wiping screws may be applied.

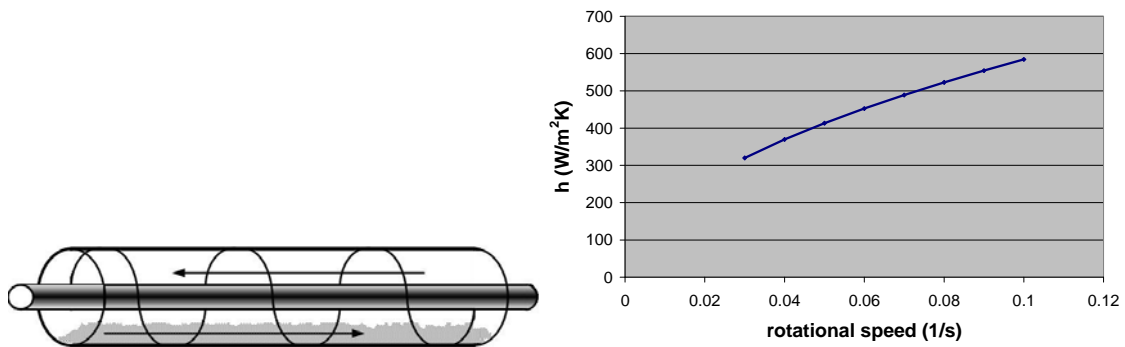

Fig. 6. (a) TCM extruder reactor, (b) extruder heat transfer (Jephson model, in (Kalbasenka, 2008))

For the case of dehydration of the TCM, assuming that the heat transport would be the limiting factor for the power, for a 3kW reactor and an effective heat transfer to the wall of about  $550 \text{ W/m}^2\text{K}$ , this would lead to a reactor of about 1 m in length and 5 cm diameter, in which about 75% of the open volume would be filled with TCM.

#### 4.3 TCM bulk flow reactor system

In a bulk flow reactor (see Fig. 7), the TCM powder flows by means of gravity along a number of vertical plate heat exchangers. This concept has the lowest auxiliary energy use and allows for long reaction times, while heat and vapour transport may be optimised by keeping the layers of active material sufficiently thin (having a sufficiently large heat exchange area). However, special provisions will be required for the vapour transport and there is some risk of the TCM sticking to the heat exchanger plates. In addition, the system will need an active means to transport the TCM powder to the top of the reactor.

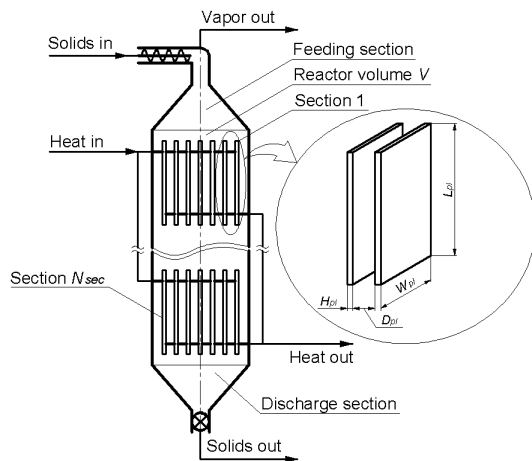

Fig. 7. TCM bulk flow reactor

For this system, no reliable value for the heat transfer between powder and plates was found in the literature. Therefore, a value of  $300 \text{ W/m}^2\text{K}$  was assumed, being the lower limit for an extruder reactor, with the reasoning that also in the bulk flow concept some mixing of the material occurs. For the case of dehydration of the TCM, assuming that the heat transport would be the limiting factor for the power, for a 3kW reactor, this would lead to a reactor of about 20 cm in length and 10 cm x 10 cm base area, in which 50% of the reactor volume would consist of 11 parallel heat exchanger plates and the remaining volume would be filled up with TCM.

## 5. Conclusion

The practical realization of a separate thermochemical reactor would increase the feasibility of seasonal storage of solar heat in thermochemical materials. The present paper focuses on the boundary conditions for such a reactor and on reactor concepts that could fulfil these boundary conditions. Three compact powder reactor concepts for dehydration are shown. Further research is necessary to establish the practical feasibility of these reactor concepts for thermochemical storage.

## References

- [1] Visscher, K., Veldhuis, J.B.J., Oonk, H.A.J., Van Ekeren, P.J., Blok, J.G. (2004), Compacte chemische seizoensopslag van zonnearmte, ECN report C04074
- [2] H.A. Zondag, A.N. Kalbasenka, M. Bakker, R. Schuitema, V.M. van Essen, W.G.J. van Helden (2008), A first study into design aspects for reactors for thermochemical storage of solar energy, Proceedings OTTI-Symposium Thermische Solarenergie.
- [3] V.M. van Essen, H. A. Zondag, R. Schuitema, W.G.J. van Helden, C.C.M. Rindt (2008), Materials for thermochemical storage: characterization of magnesium sulfate, Proceedings Eurosun 2008.
- [4] A.N. Kalbasenka (2008), Basis calculations of reactor concepts, ECN memo

## Acknowledgement

This project has received financial support from the Dutch Ministry of Economic Affairs by means of the EOS support scheme. The work on thermochemical heat storage is part of the long-term work at ECN on compact storage technologies.